

FEATURES

- The valves are certified according to IEC 61508 Functional Safety data and have SIL-3 capability (TÜV & Exida certification)
- The solenoid valves are recommended for pilot applications with basic flow, wide pressure ranges and no minimum operating pressure
- PTFE rider rings and graphite-filled PTFE seals reduce friction and eliminate sticking
- Coils used in metal enclosures have class H insulation materials
- Dedicated execution for low power
- Dedicated execution for extreme low ambient temperatures
- Peak voltage suppression diodes are standard in DC solenoids with metal enclosures
- The solenoid valves satisfy all relevant EU directives
- Manual Operators are optional including an under pressure removable type
- Environmental NACE compliant and certified vibration resistant in combination with WSCR solenoids



GENERAL

Differential pressure 0 - 10 bar [1 bar = 100kPa]
Maximum viscosity 65cST (mm²/s)
Response times 75 - 100 ms⁽¹⁾

fluids ⁽²⁾ (*)	temperature range (TS) ⁽³⁾	seal materials (*)
air, inert gas, water, oil	-20 to +120°C	FPM (fluorelastomer)
	-40 to +40°C	VMQ (silicone)
	-60 to +60°C	(F)VMQ ((fluor)silicone)

⁽¹⁾ Energising time for Ex i version booster coils will be < 2 sec (NFIS, WSNFIS and WSCRIS)
⁽²⁾ Air / inert gas only for Ex i version (NFIS, WSNFIS and WSCRIS)
⁽³⁾ Can be limited by the operator ambient temperature range for explosion proof solenoids

MATERIALS IN CONTACT WITH FLUID

(*) Ensure that the compatibility of the fluids in contact with the materials is verified

	Brass body	Stainless steel body
Body	Brass	AISI 316L SS
Stem	Stainless steel	Stainless steel
Core tube	Stainless steel	Stainless steel
Core and plugnut	Stainless steel	Stainless steel
Springs	Stainless steel	Stainless steel
Sealings & poppets	FPM, VMQ, (F)VMQ	FPM, VMQ, (F)VMQ
Rider ring	PTFE	PTFE

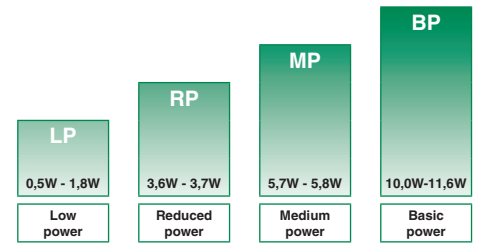
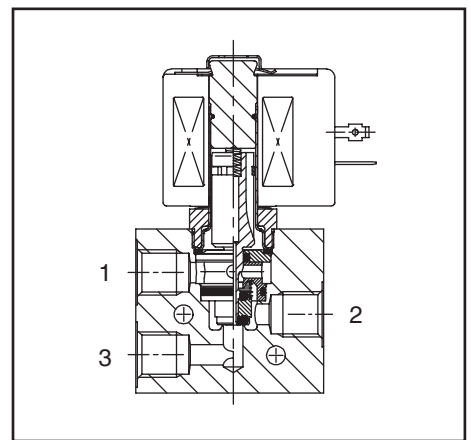

POWER LEVELS - cold electrical holding values (watt)

SPECIFICATIONS

pipe size	orifice size	flow coefficient Kv		operating pressure differential (bar)	power level	prefix optional solenoids										basic catalogue number	
						min.	max. (PS)	NEMA 7&9	ATEX / IECEx				IP65				
									air/water (*)	Ex d	Ex i	Ex e mb		Ex mb			
❖	(mm)	(m ³ /h)	(l/m)	0	~/=	EF	NF	WSCR	NFIS	WSCRIS	EM	WCREM	PV	SC	brass ⁽⁴⁾	stainless steel	
U - Universal, FPM sealings and poppets (minimum fluid temperature -20°C)⁽³⁾																	
1/4	5,7	0,45	7,5	0	10	BP	●	●	-	-	-	●	-	○	●	❖ 327B001	❖ 327B002
1/4	5,7	0,45	7,5	0	10	MP	-	●	●	-	-	●	●	-	●	❖ 327B201	❖ 327B202
1/4	5,7	0,45	7,5	0	10	RP	-	●	●	-	-	●	●	-	●	❖ 327B101	❖ 327B102
1/4	5,7	0,45	7,5	0	10 ⁽²⁾	LP	-	○	○	○	○	-	○	-	-	❖ 327B301	❖ 327B302
U - Universal, VMQ sealings and poppets (minimum fluid temperature -40°C)⁽³⁾																	
1/4	5,7	0,45	7,5	0	10	BP	●	●	-	-	-	●	-	○	●	❖ 327B011	❖ 327B012
U - Universal, (F)VMQ sealings and poppets (minimum fluid temperature -50°C)⁽³⁾																	
1/4	5,7	0,45	7,5	0	10	MP	-	-	-	-	-	●	-	-	●	❖ 327B211	❖ 327B212
1/4	5,7	0,45	7,5	0	10	RP	-	●	●	-	-	●	●	-	●	❖ 327B111	❖ 327B112
1/4	5,7	0,45	7,5	0	10 ⁽²⁾	LP	-	○	○	○	○	-	-	-	-	❖ 327B311	❖ 327B312
U - Universal, (F)VMQ sealings and poppets (minimum fluid temperature -60°C)⁽³⁾																	
1/4	5,7	0,45	7,5	0	10	MP	-	●	●	-	-	-	●	-	-	❖ 327B291	❖ 327B292

❖ Select 8 for NPT ANSI 1.20.3 or Select G for ISO G(228/1) ● Available feature ○ Available feature in DC only - Not available
⁽²⁾ Air / inert gas only for Ex i version (NFIS, WSNFIS and WSCRIS) ⁽³⁾ For maximum ambient temperature check operator ambient temperature range on page 3
⁽⁴⁾ Not in combination with WSCR solenoids

PREFIX TABLE

prefix							description	power level			
1	2	3	4	5	6	7		LP	RP	MP	BP
E	F						Explosionproof - NEMA 7, 9 - Zinc plated steel conduit	-	-	-	●
E	V						Explosionproof - NEMA 7, 9 - 316 SS conduit	-	-	-	●
E	M						Waterproof IP66/67 - Metal enclosure (EN/IEC 60079-7,-18 and -31)*	-	●	●	●
		E	T				Threaded conduit/hole (M20 x 1,5)	●	●	●	●
N	F						Flameproof - Aluminium (EN/IEC 60079-1, 60079-31)*	○	●	●	●
P	V						Encapsulated epoxy moulded (EN/IEC 60079-18)*	-	-	-	○
S	C						Solenoid with spade plug connector (EN/IEC 60730)	-	●	●	●
W	P						Waterproof IP67 - Metal enclosure	-	●	●	●
N	F			I	S		I.S. with Aluminium IP66/IP67 enclosure (EN/IEC 60079-11+31)*	○	-	-	-
W	S						Waterproof IP67 - 316 SS enclosure	-	●	●	●
W	S	C	R				Flameproof 316L SS (EN/IEC 60079-0+1+31)*	○	●	●	-
W	S	C	R	E	M		Increased Safety / Encapsulated 316L SS (EN/IEC 60079-0+7+18+31)*	○	●	●	-
W	S	C	R	I	S		Intrinsically Safe 316L SS (EN/IEC 60079-0+11+31)*	○	-	-	-
W	S	E	M				Waterproof IP66/67 - 316 SS enclosure (EN/IEC 60079-7,-18 and -31)*	-	●	●	●
W	S	N	F	I	S		I.S. with 316L SS IP66/IP67 enclosure (EN/IEC 60079-11+31)*	○	-	-	-
W	S	N	F				Flameproof 316L SS (EN/IEC 60079-1, 60079-31)*	○	●	●	●
		T					Threaded conduit (1/2" NPT)	●	●	●	●
				H	C		Class H - Battery charging circuit	-	-	-	●
					X		Other special constructions	-	●	●	●

PRODUCT SELECTION GUIDE

STEP 1

Select basic catalogue number, including pipe thread identification letter. Refer to the specifications table on page 1.

Example: 8327B001

STEP 2

Select prefix (combination). Refer to the specifications table on page 1 and the prefix table on page 2, respect the indicated power level.

Example: NF

STEP 3

Select suffix (combination) if required. Refer to the suffix table on page 2, respect the indicated power level.

Example: MS

STEP 4

Select voltage. Refer to standard voltages on page 3.

Example: 230V / 50/60Hz

STEP 5

Final catalogue / ordering number.

Example:

NF 8327B001 MS 230V / 50/60 Hz

SUFFIX TABLE

suffix					description	power level			
1	2	3	4	5		LP	RP	MP	BP
N	V				FPM (fluoroelastomer) and parts cleaned for oxygen service	●	●	●	●
V					FPM (fluoroelastomer)	●	-	-	-
	C	O			Epoxy coating on all external surfaces	●	●	●	●
			M	O	Push type manual operator ⁽²⁾	●	●	●	●
			M	S	Screw type manual operator ^{(1) (2)}	●	●	●	●

● Available feature

○ Available feature in DC only

- Not available

* ATEX/IECEx valves using these solenoids are approved according to EN 13463-1 (non electrical)

⁽¹⁾ Functional Safety certification is not applicable with this feature

⁽²⁾ Under pressure removable execution (see page 6)

OPTIONS & ACCESSORIES

catalogue number	spare part kit no. ⁽²⁾	mounting bracket
	~ / =	
SC ❖327B001	C123670	■
SC ❖327B002	C123670	■
SC ❖327B011	C131237	■
SC ❖327B012	C131237	■
SC ❖327B101	C132251	■
SC ❖327B102	C132251	■
SC ❖327B111	C132253	■
SC ❖327B112	C132253	■
SC ❖327B201	C132251	■
SC ❖327B202	C132251	■
SC ❖327B211	C132253	■
SC ❖327B212	C132253	■
❖327B291	C325957	■
❖327B292	C325957	■
❖327B301	C133441	■
❖327B302	C133441	■
❖327B311	C133442	■
❖327B312	C133442	■

❖ Select 8 for NPT ANSI 1.20.3 or select G for ISO G(228/1)

⁽²⁾ Standard prefixes/suffixes are also applicable to kits

■ Mounting holes in body

ORDERING EXAMPLES VALVES:

SC	8	327B001	24V / DC
WSEMT	G	327B002	MS 24V / DC
NFET	G	327B001	MS 230V / 50/60 Hz
WSEM	G	327B002	MO 24V / DC
NF	8	327B211	24V / DC
WSCR	G	327B202	MS 24V / DC
EM	8	327B201	MS 230V / 50/60 Hz
PV	8	327B012	MS 24V / DC
EF	G	327H002	MS 240V / 50/60 Hz

prefix ⁽³⁾ pipe thread basic number ⁽³⁾ voltage suffix

ORDERING EXAMPLES KITS:

	C131237 ⁽⁴⁾	
WSEM	C123670	MS
NF	C131237	
WSEM	C123670	MO

prefix basic number suffix

⁽³⁾ Prefix EF and EV should always be used in conjunction with change letter H in the basic number

⁽⁴⁾ Basic kit number applies to SC coil construction

EXPLANATION OF TEMPERATURE RANGES OF SOLENOID VALVES

Valve temperature range The valve temperature range (TS) is determined by the selected seal material, the temperature range for proper operation of the valve and sometimes by the fluid (e.g. steam)

Operator ambient temperature range The operator ambient temperature range is determined by the selected power level and the safety code

Total temperature range The temperature range of the complete solenoid valve is determined by the limitations of both temperature ranges above

ELECTRICAL CHARACTERISTICS

Coil insulation class H

Electrical safety IEC 335

Standard voltages DC (=) 24V - 48V; Allowable voltage variation ± 10%
AC (~) 24V - 48V - 115V - 230V/50/60Hz; Other voltages are available on request

prefix option	power ratings				operator ambient temperature range (C°) ⁽¹⁾	safety code	electrical enclosure protection (EN 60529)	replacement coil / kit		type ⁽²⁾	
	inrush ~		holding ~					=	~		=
	(VA)	(VA)	(W)	(W)							
Basic power (BP)											
SC	10,0	10,0	10,0	9,0/11,2	-40 to +55	EN 60730	IP65, moulded	123664-017	400425-142	01	
WP/WS	10,0	10,0	10,0	9,0/11,2	-40 to +55	EN 60730	IP67, steel /SS	400915-017	400913-142	03	
NF/WSNF	10,0	10,0	10,0	9,0/11,2	-60 to +40/60	II2G Ex d IIC Gb T6/T5, II2D Ex tb IIIC Db	IP66/67, alu./SS	400915-017	400913-142	05	
EM/WSEM	10,0	10,0	10,0	9,0/11,2	-40 to +40	II2G Ex e mb IIC Gb T3, II2D Ex tb IIIC Db	IP66/67, steel /SS	400915-017	400913-142	03	
PV	-	-	-	9,0/11,2	-40 to +55	II2G Ex mb IIC Gb T4, II2D Ex mb IIIC Db	IP65, moulded	-	- ⁽³⁾	07	
EF/EV	12,0	12,0	12,0	9,3/11,6	-40 to +52/40	NEMA type 7 and 9	NEMA 4X	276002-058D	238714-006D	08	
Medium Power (MP)											
SC	5,8	5,8	5,8	5,2/5,7	-40 to +90	EN 60730	IP65, moulded	400924-297	400923-442	02	
WP/WS	5,8	5,8	5,8	5,2/5,7	-40 to +90	EN 60730	IP67, steel /SS	400921-297	400914-442	04	
NF/WSNF	5,8	5,8	5,8	5,2/5,7	-60 to +60/75/90	II2G Ex d IIC Gb T6/T5/T4, II2D Ex tb IIIC Db	IP66/67, alu./SS	400921-297	400914-442	05	
WSCR	5,8	5,8	5,8	5,2/5,7	-60 to +40/75/90	II2G Ex d IIC Gb T6/T4/T3, II2D Ex t IIIC Db	IP66/67, SS	400962-297	400961-442	06	
WSCREM	5,8	5,8	5,8	5,2/5,7	-60 to +40/90	II2G Ex e mb IIC Gb T6/T4, II2D Ex tb IIIC Db	IP66/67, SS	400962-297	400961-442	06	
EM/WSEM	5,8	5,8	5,8	5,2/5,7	-40 to +40/75	II2G Ex e mb IIC Gb T5/T4, II2D Ex tb IIIC Db	IP66/67, steel /SS	400921-297	400914-442	04	
Reduced Power (RP)⁽⁴⁾											
SC	3,7	3,7	3,7	3,2/3,6	-40 to +55	EN 60730	IP65, moulded	- ⁽⁴⁾	400923-042	02	
WP/WS	3,7	3,7	3,7	3,2/3,6	-40 to +55	EN 60730	IP67, steel /SS	- ⁽⁴⁾	400914-242	04	
NF/WSNF	3,7	3,7	3,7	3,2/3,6	-60 to +60	II2G Ex d IIC Gb T6, II2D Ex tb IIIC Db	IP66/67, alu./SS	- ⁽⁴⁾	400914-242	05	
WSCR	3,7	3,7	3,7	3,2/3,6	-60 to +40/60/90	II2G Ex d IIC Gb T6/T5/T4, II2D Ex t IIIC Db	IP66/67, SS	- ⁽⁴⁾	400961-242	06	
WSCREM	3,7	3,7	3,7	3,2/3,6	-60 to +40/60/90	II2G Ex e mb IIC Gb T6/T5/T4, II2D Ex tb IIIC Db	IP66/67, SS	- ⁽⁴⁾	400961-242	06	
EM/WSEM	3,7	3,7	3,7	3,2/3,6	-40 to +40/55	II2G Ex e mb IIC Gb T6/T5, II2D Ex tb IIIC Db	IP66/67, steel /SS	- ⁽⁴⁾	400914-242	04	
Low Power (LP)⁽⁵⁾											
NF/WSNF	1,85	1,85	1,85	1,5/1,8	-60 to +55	II2G Ex d IIC Gb T6, II2D Ex tb IIIC Db	IP66/67, alu./SS	- ⁽⁵⁾	400914-542	05	
WSCR	1,85	1,85	1,85	1,5/1,8	-60 to +55	II2G Ex d IIC Gb T6, II2D Ex t IIIC Db	IP66/67, SS	- ⁽⁵⁾	400961-542	06	
WSCREM	1,85	1,85	1,85	1,5/1,8	-60 to +55	II2G Ex e mb IIC Gb T6, II2D Ex tb IIIC Db	IP66/67, SS	- ⁽⁵⁾	400961-542	06	
NFIS ⁽⁶⁾⁽⁸⁾	0,5	0,5	0,5	0,5	-40 to +60	II2G Ex ia IIC T6 Gb, II2D Ex tb IIIC Db	IP66/67, alu./SS	- ⁽⁷⁾	429013-001	05	
WSCRIS ⁽⁶⁾	0,5	0,5	0,5	0,5	-40 to +60	II2G Ex ia IIC T6 Gb, II2D Ex tb IIIC Db	IP66/67, SS	- ⁽⁷⁾	429013-001	06	
WSNFIS ⁽⁶⁾	0,5	0,5	0,5	0,5	-40 to +60	II2G Ex ia IIC T6 Gb, II2D Ex tb IIIC Db	IP66/67, alu./SS	- ⁽⁷⁾	429013-001	05	

⁽¹⁾ Temperature range can be limited by sealings
⁽²⁾ Refer to the dimensional drawings on page 4 and 5
⁽³⁾ Multiple coil kits are available under ATEX/IECEx, contact us
⁽⁴⁾ AC (~) limited to 127V/50/60Hz or 125V/DC
⁽⁵⁾ Only available in 24, 48 and 110V/DC
⁽⁶⁾ Shall be protected against any impact or friction, see the installation conditions given in the I&M sheet
⁽⁷⁾ Only available in 24V/DC
⁽⁸⁾ For safety and nominal electrical parameters refer to applicable solenoid page or I&M sheet
- Not available

ELECTRICAL CONNECTIONS

prefix	connection
SC	Spade plug connector with cable gland EN175301-803A (ISO 4400) for cables with an outer diameter from 6 to 10 mm
WP, WS, EM, WSEM, NFIS, WSNFIS, WSCRIS	M20 plastics cable gland for cables with an outer diameter from 7 to 12 mm.
WSCREM	M20 316 SS cable gland for cables with an outer diameter from 7,2 to 11,7 mm.
NF, WSNF, WSCR, NFTIS, WSNFTIS	1/2" NPT threaded cable entry. Enclosures are supplied without cable gland
NFET, WSNFET, NFETIS, WSNFETIS	M20 x 1,5 threaded cable entry. Enclosures are supplied without cable gland

ADDITIONAL OPTIONS

- Ex mb/mD (prefix "PV") solenoid can be supplied with various cable lengths
- Compliance with "UL", "CSA" and other local approvals available on request
- Manual Operators are available as shown on page 6

INSTALLATION

- Multi language installation/maintenance instructions are included with each valve
- The solenoid valves can be mounted in any position without affecting operation
- The mounting holes are provided in the valve body
- Threaded pipe connection identifier is 8 = NPT (ANSI 1.20.3); G = G (ISO 228/1)
- Declarations of conformity are available on request
- Ex e mb Prefix "EM" and Ex ia Prefix "NFIS/WSCRIS" execution: solenoid enclosure has a cable gland with integral strain relief for cables with an o.d. from 7 to 12 mm and housing is provided with an internal and external connection facility for an earthing or bonding conductor
- Ex d Prefix "NF/WSNF/WSCR" enclosure is provided with a 1/2" NPT threaded entry hole, M20 x 1,5 (prefix "ET") is optional. These are supplied without cable gland
- All DC solenoids with metal enclosure are provided with switch-off peak voltage suppression diodes
- To comply with IEC 61508 (SIL) the valves must be provided with a specific exhaust protector (as shown on page 6) or equal

DIMENSIONS (mm), WEIGHT (kg)



TYPE 01:
Epoxy moulded
SC: IEC 335 / ISO 4400

327B001 / B002 / B011 / B012

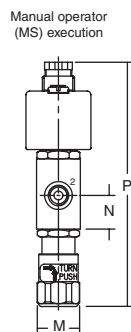
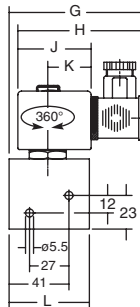
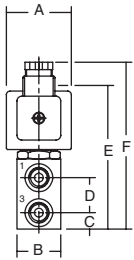

TYPE 02:
Epoxy moulded
SC: IEC 335 / ISO 4400

327B101 / B102 / B111 / B112 / B201 / B202 / B211 / B212

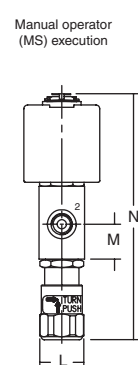
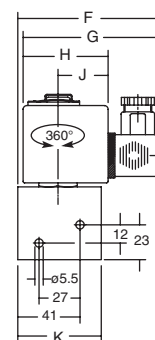
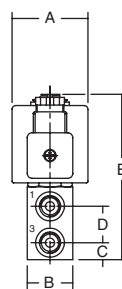

TYPE 03:
Metal, epoxy coated / AISI 316 SS
WP / WS: IEC 335
EM / WSEM: EN/IEC 60079-7+18+31

327B001 / B002 / B011 / B012

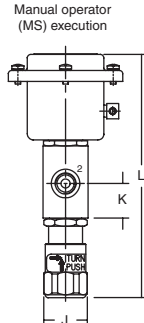
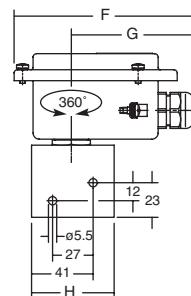
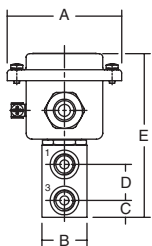

TYPE 04:
Metal, epoxy coated / AISI 316 SS
WP / WS: IEC 335
EM / WSEM: EN/IEC 60079-7+18+31

327B101 / B102 / B111 / B112 / B201 / B202 / B211 / B212

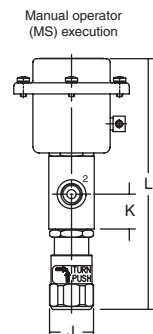
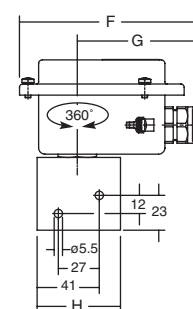
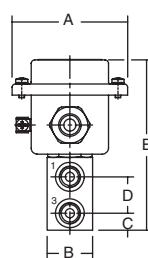

DIMENSIONS (mm), WEIGHT (kg)



TYPE 05:
 Aluminium, epoxy coated / AISI 316L SS
 NF / WSNF : EN/IEC 60079-1, 60079-31
 NFIS / WSNFIS : EN/IEC 60079-11, 60079-31

327B001 / B002 / B011 / B012 / B101 / B102 / B111 / B112 / B201
 327B202 / B211 / B212 / B291 / B292 / B301 / B302 / B311 / B312

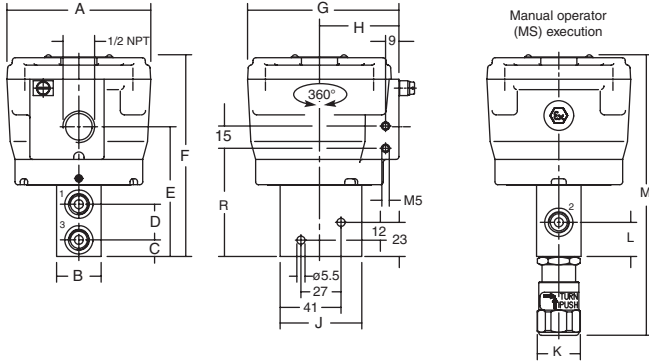

TYPE 06:
 AISI 316L SS
 WSCR : EN/IEC 60079-0, 60079-1, 60079-31
 WSCREM : EN/IEC 60079-0, 60079-7, 60079-18,
 EN/IEC 60079-31
 WSCRIS : EN/IEC 60079-0, 60079-11, 60079-31

327B102 / B112 / B202 / B212 / B292 / B302 / B312

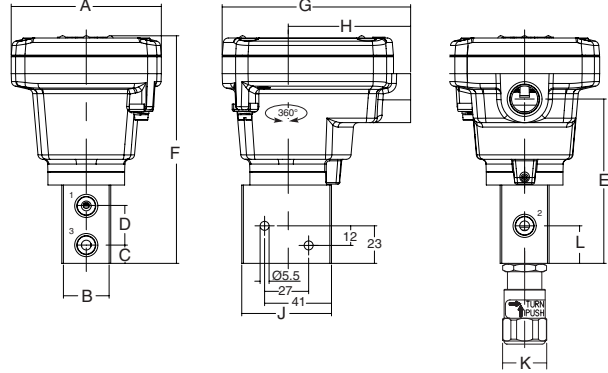

TYPE 07:
 Epoxy encapsulated
 PV: EN/IEC 60079-18

327B001 / B002 / B011 / B012

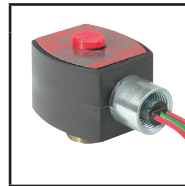
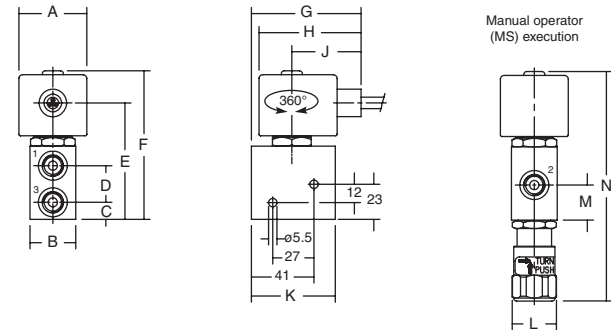

TYPE 08:
 Epoxy encapsulated
 EF and EV: NEMA type 7, 9 / ICS-6 ANSI

327H001 / H002 / H011 / H012

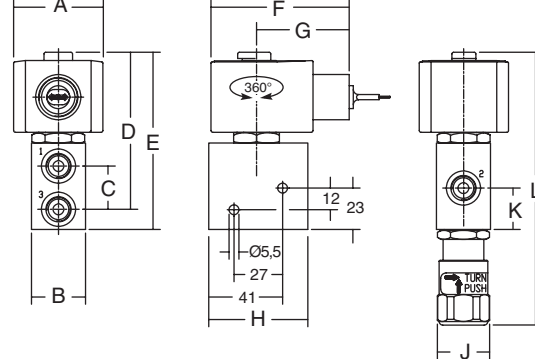

type	prefix/option	power level	A	B	C	D	E	F	G	H	J	K	L	M	N	P	R	weight
01	SC	BP	45	30	11	24	90	114	91	85	50	30	55	29	23	167	-	0,95 kg
02	SC	MP/RP	50	30	11	24	109	95	87	56	53	55	29	23	162	-	-	1,05 kg
03	WP, WS, EM, WSEM	BP	77	30	11	24	109	120	81	55	29	23	162	-	-	-	-	1,00 kg
04	WP, WS, EM, WSEM	MP/RP	77	30	11	24	112	120	81	55	29	23	165	-	-	-	-	1,30 kg
05	NF	BP/MP/RP	97	30	11	24	87	136	102	54	55	29	23	189	-	-	73	2,60 kg
05	WSNF	BP/MP/RP	97	30	11	24	87	136	102	54	55	29	23	189	-	-	73	3,70 kg
05	NF, NFIS	LP	97	30	11	24	97	146	102	54	55	29	23	199	-	-	83	2,65 kg
05	WSNF, WSNFIS	LP	97	30	11	24	97	146	102	54	55	29	23	199	-	-	83	3,75 kg
06	WSCR, WSCREM, WSCRIS	MP/RP/LP	92	30	11	24	101	140	116	75	55	29	23	-	-	-	-	3,10 kg
07	PV	BP	45	30	11	24	76	97	72	67	45	55	29	23	150	-	-	1,05 kg
08	EF, EV	BP	50	30	24	87	98	77	51	55	29	23	151	-	-	-	-	0,95 kg

SECTIONAL DRAWINGS

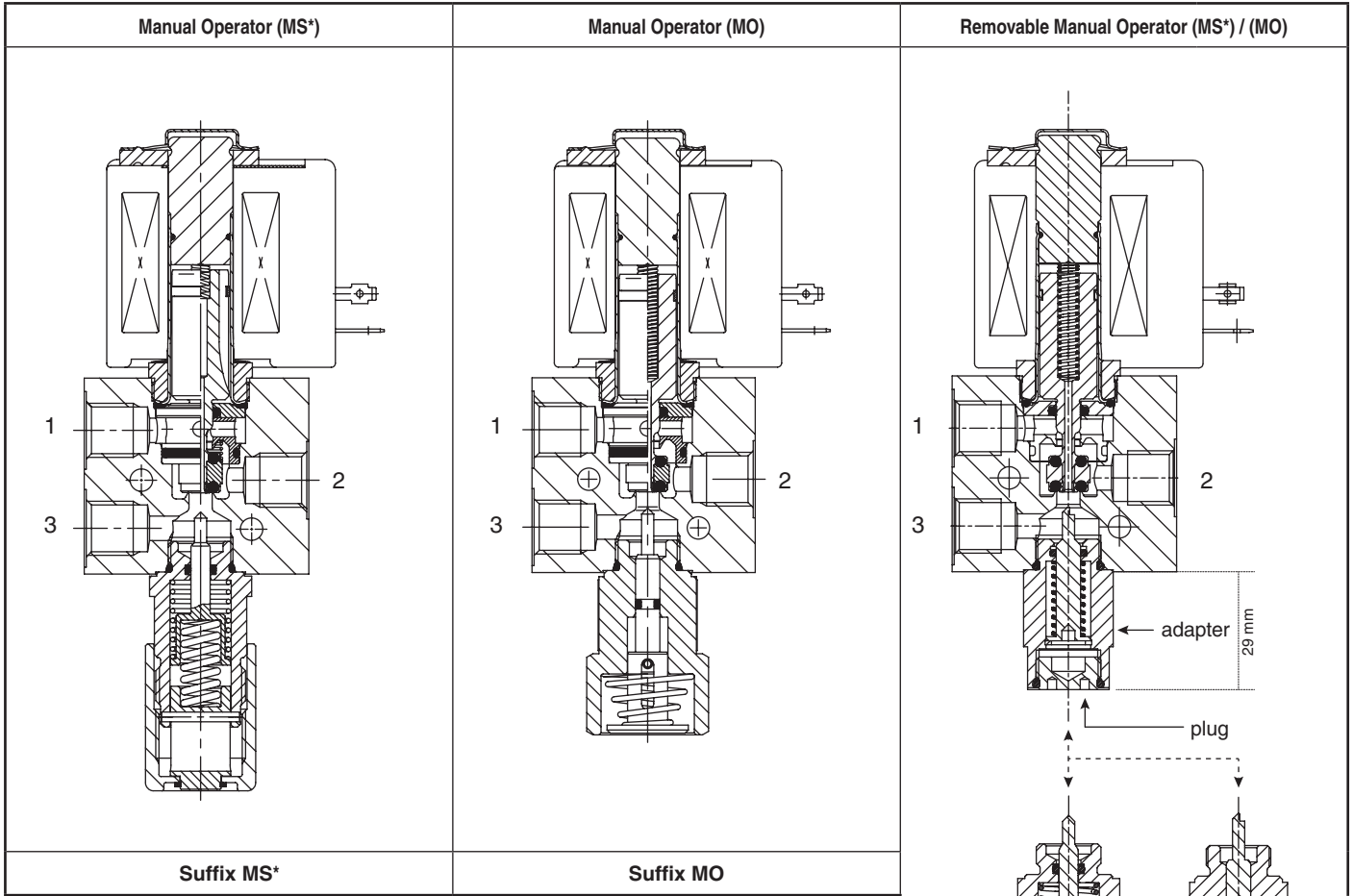

REMOVABLE MO / MS TOOL

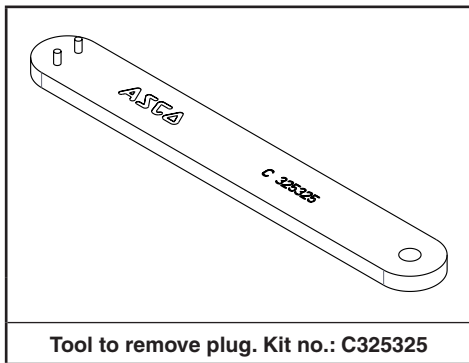

NF/WSNF MOUNTING BRACKET

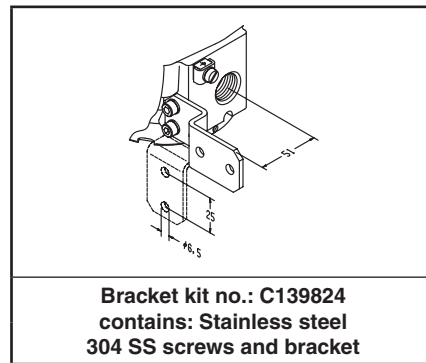

Removable Manual Operator	Kit number
MS type	C325324
MO type	C325323
Adapter type	C325410

* MS type is not covered in the Functional Safety (SIL) certification

EXHAUST PROTECTOR

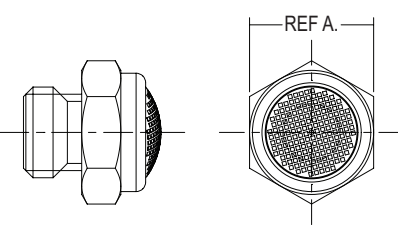
pipe size	thread	part number		mesh/filtering	wrench size (REF A.)	
		brass nickel plated	316L stainless steel			
1/4	ISO 228/1	131875-001	131875-014	100 - 200 µm	16 mm	
	NPT	131875-002	131875-015			